

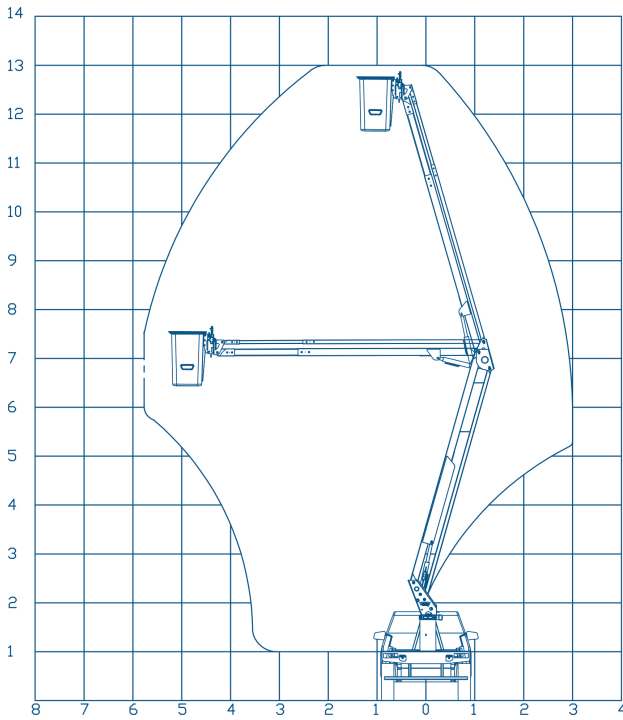

WORK CHART

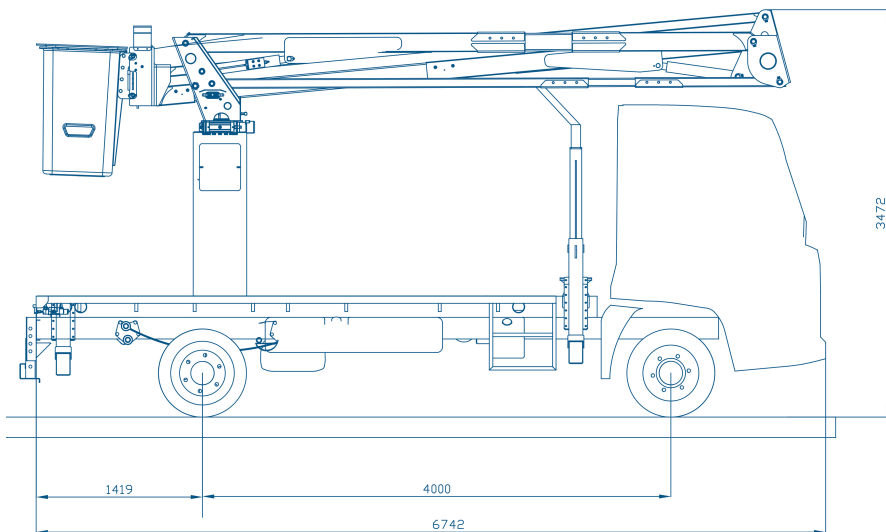

- BASKET ROTATION
0°
- STABILIZERS
2 x A
- MAX HEIGHT
13,0 m
- BASKET HEIGHT
11,5 m
- SIDE REACH
6 m
- WEIGHT CAPACITY
136 kg
- BASKET SIZE
0,7 x 0,7 x 1,1 m
- CONTROL
HYDRAULIC
- ROTATION
360°
- P.B.T.
5.000 kg



THE UNIQUE AND INNOVATIVE PLATFORM

EQUIPMENT OF SERIES

Product Description

We present the proposal of the **SOCAGE forSte 13Ai** articulated aerial platform. High quality steel frame. Above the chassis is the base that supports the structure.

Simple pantograph bars group: The group allows the reduction of the installation width, a distribution of stabilizing loads allows to overcome intermediate obstacles between the equipment and the work area. The two articulated bars are the connecting elements between the rotating tower and the main telescopic boom.

Operational Boom: Boom in tubular execution, with working area from -5° to +80° based on the horizontal. All hydraulic tubes are located inside the boom, so there are no external elements that can be damaged by impacts or collisions against obstacles during the various work phases.

Basket Leveling: System with mechanical leveling bar, activated along with the articulated platform boom

Leveling Bar: Basket leveling system without the use of chains, considerably reducing the volume and cost of maintenance.

Basket Access: Positioning the manufactured basket for ease of access and eventual rescues.

Technical Characteristics

- Fiberglass basket
- Hydraulic controls
- 2 stabilizer blades
- Insulation class "C" 46kV - "B" 69kV

Security Devices

- Emergency stop buttons
- Emergency lowering hand pump
- Flanged check valves on all cylinders
- Maximum pressure valves on hydraulic system
- Thermal protections on the electrical system
- Hooks for safety belts in the basket
- Remote controls, basket, engine activation or stop and vehicle horn.



Socage do Brasil follow the rules NR12 XII, ANSI A92.2-2015 and ABNT NBR: 16092 12/2018

