

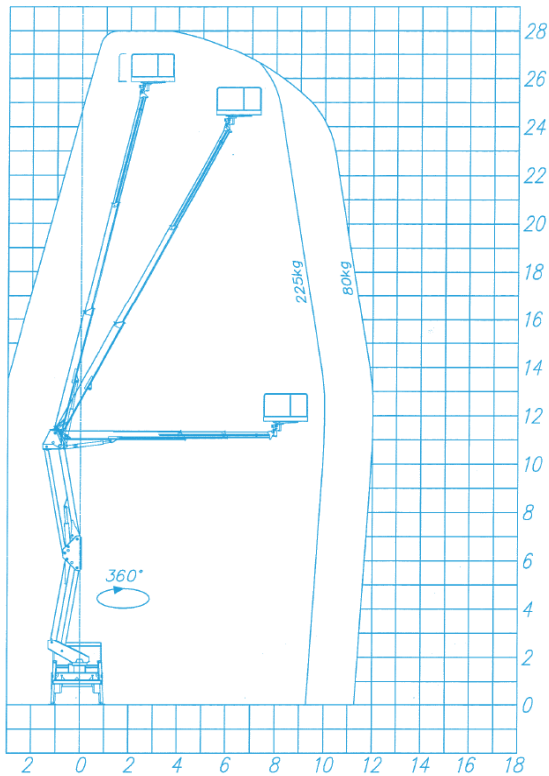

WORK CHART



- STABILIZERS
HE + HE
- MAX HEIGHT
28,0 m
- BASKET HEIGHT
26,0 m
- SIDE REACH
16,0 m
- WEIGHT CAPACITY
225 kg
- BASKET SIZE
1,8 x 0,7 x 1,1 m
- CONTROL
HYDRAULIC
- ROTATION
360°
- P.B.T.
5.600kg / 7.000 kg

THE UNIQUE AND INNOVATIVE PLATFORM

EQUIPMENT OF SERIES

Product Description

Introducing the **SOCAGE DA328 forSte** Bi-Telescopic Boom Double Articulated Aerial Platform. High quality steel frame. Above the chassis is the base that supports the structure.

Boom tower: Made of sheet steel, composed of a folded main body and electro-welded reinforcements. It is installed on the base that supports the structure.

Rotation: Rotation is guaranteed by the base set, hydraulic motor and worm screw, with a maximum of 7 turns in each direction of rotation.

Basket leveling: System with mechanical leveling bar, activated along with the articulated platform boom

Double pantograph bar group: Allows for the reduction of the installation width, a distribution of stabilizing loads allows to overcome obstacles between the equipment and the work area.

Operational boom: Boom in tubular design, with a working area from -25° to +70° on a horizontal base.

Hydraulic installation supply: Hydraulic pump supply coupled to the truck's power take-off

Controls: Fully hydraulic controls, located on the base and in the basket, Electric hourmeter in the vehicle cabin

Technical Characteristics

- Aluminum basket
- Proportional Hydraulic Controls
- High quality steel frame
- 360° tower rotation

Security Devices

- Emergency stop buttons
- Emergency lowering hand pump
- Manual commands
- Shielded shut-off valve on all cylinders
- Maximum pressure valves on hydraulic system
- Hooks for safety belts in the basket
- Basket control equipped with horn and vehicle engine starting stop

Equipment Options

- 1 Kv Insulation / Polyethylene Basket

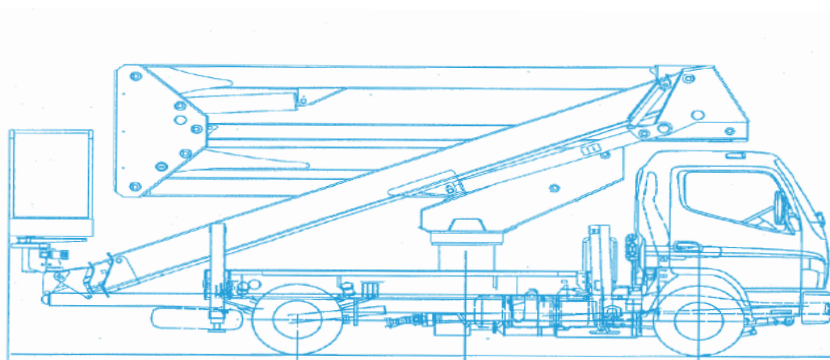

Socage do Brasil follows regulatory standards NR12 XII, ANSI A92.2-2015, ABNT NBR: 16092:2018

